

# An Efficient Optimisation Method Based On Genetic Algorithm Applied To Reduce Greenhouse Gases in Power System

Djemai Naimi <sup>#1</sup>, Salhi Ahmed <sup>#1</sup>, Tarek Bouktir <sup>\*2</sup>

<sup>1</sup>Electrical Engineering Laboratory (LGEB), Biskra University (Algeria),

<sup>2</sup>Department of Electrical Engineering, Setif University (Algeria)

<sup>1</sup>d.naimi@univ-biskra.dz

<sup>2</sup>a\_salhi\_m@yahoo.fr

<sup>3</sup>tarek.bouktir@esrgroups.org

**Abstract**— *In order to reduce greenhouse gases caused by fossil thermal generating units in power system, this paper proposes a strategy by an emission dispatching optimization based on genetic algorithm GA and successive linear programming. The main idea of this proposed hybrid method consists to combine an evolutionary and a conventional method in order to reap profit from their both advantages. A widely known model of power system network IEEE thirty-bus test system is used to demonstrate the proposed technique. In solving the resulting optimization problems, MATLAB's Genetic Algorithm Toolbox and MATPOWER3.2 were employed. This paper demonstrates performance improvements for this approach by comparisons with several optimization methods.*

**Keywords**— *Greenhouse gases, Power system, emission dispatching Optimization, Genetic Algorithm, Successive Linear programming.*

## I. INTRODUCTION

Fossil fuels provide a reliable and affordable source of energy. The technology for exploitation of fossil fuels is well developed and available in virtually every country of the world. However, one of the main contributions to the emission of greenhouse gases into the atmosphere, which is thought to be responsible for climate change on our environment, is through the use of fossil-fuelled power plants [1], [2].

In recent years, the emission dispatching has received much attention from thermal power plants which have forced the utilities to modify their operational strategies. Several strategies to reduce the atmospheric emissions have been proposed and discussed in literature [3], [4] and [5].

Different techniques have been reported in the literature concerning to the emission/economic

dispatch problem[6] based on evolutionary algorithms such as Neural Networks ,Genetic algorithm (GA) and others witch it's use for problem solving is not new. The pioneering work of J. H. Holland in the 1970's proved to be a significant contribution for scientific and engineering applications [7]. Since then, the output of research work in this field has grown exponentially although the contributions have been, and are largely initiated, from academic institutions world-wide.

The conventional methods of optimization are also widely used in optimization of power flow (OPF) calculations such as interior point, simplex , Lagrange and successive linear programming SLP[8]; this last method is subject of this study used in MATPOWER which is a package of MATLAB files for solving power flow and optimal power flow problems. It is a simulation tool for researchers and educators which is easy to use and modify [9]

In this paper, a hybrid approach based on evolutionary algorithms (GA) and conventional method (SLP) is proposed to solve emission limitations problem. The proposed hybrid approach GASLP is applied on a case study based on the standard IEEE 30-bus system; it is conducted via simulation based on MATLAB7.9.0 with the Genetic Toolbox and MATPOWER3.2.

After a brief overview of optimization power flow methods (OPF), the rest of the paper is organized as follows: formulation of the problem of optimization of gas emission with different constraints given in Section3, test system and it's characteristics with the GA parameters are introduced in Section 4. Obtained numerical results are presented and discussed in

Section 5 and finally, Section 6 provides a conclusion and discusses possible future research.

## II. OVERVIEW OF OPTIMIZATION POWER FLOW METHODS

In this section, we focus only on two optimization power flow methods:

### A. Genetic Algorithm

Genetic Algorithm (GA) is a search technique that mimics the mechanisms of natural selection [10],[11]. Cell is the building unit of all living organisms. In each cell there is a set of chromosomes which are strings of DNA. Every chromosome consists of genes which encode a particular protein. During reproduction, first occurs crossover. Genes from parents form in some way the whole new chromosome. However, the new created offspring can be mutated. Mutation occurs when the elements of DNA are a bit changed.

These changes are mainly caused by errors in copying genes from parents. The fitness of an organism is measured by success of the organism in its life. With generations, the good characteristics remain and the bad ones died which represents "The survival of the fittest". The following figure describes shortly the important steps in GA method.

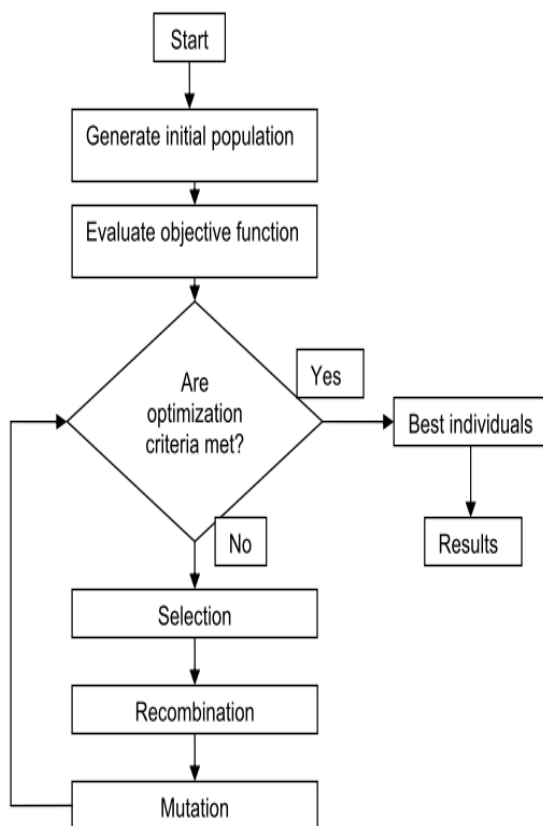

Fig. 1 Genetic algorithm flow chart

### B. successive linear programming SLP

Because of the nonlinear nature of the electric power system, the problem of optimization of power flow OPF is a nonlinear programming problem. Its resolution requires therefore a nonlinear optimization technique such as Newton's method. Another widely used method is the successive linear programming (SLP) technique [12],[13]. In the SLP approach, the OPF problem is linearized around the current operating point.

This linearized problem is solved to get incremental changes in the control vector. The control vector is updated, and using a load flow, the new state is computed. This process is successively repeated until the desired objective is achieved [12].

### III. PROBLEM FORMULATION

The goal of optimization power flow in this study is looking for a minimal value of emission function while satisfying a set of constraints such a voltage magnitude and power limits.

The standard OPF can be written as follow:

$$\begin{cases} \text{Min} : Fe(P_g) \\ \text{subject to} : \\ g(x) = 0 \\ \text{and} \\ h(x) \leq 0 \end{cases} \quad (1)$$

Where  $F_e$  is emission function of generator output represents SO<sub>2</sub> and NO<sub>x</sub> emission and is expressed in ton/h or Kg/h;  $g(x)$  and  $h(x)$  are respectively equality and inequality constraints.

In our case the OPF can take the following form:

$$\begin{cases} \text{Min} : Fe(P_g) = \sum_{i=1}^6 (\alpha_i + \beta_i P_{gi} + \gamma_i P_{gi}^2 + \varepsilon_i e^{\delta_i} P_{gi}) \\ \text{subject to} : \\ \sum_{i=1}^6 P_{gi} - P_D - T_L = 0 \\ \text{and} \\ P_{gi}^{\min} \leq P_{gi} \leq P_{gi}^{\max} \\ V_i^{\min} \leq V_i \leq V_i^{\max} \end{cases} \quad (2)$$

Where  $\alpha_i$ ,  $\beta_i$ ,  $\gamma_i$  and  $\delta_i$  are coefficients of the  $i^{\text{th}}$  generator emission characteristics. It must be noted that these parameters are determined by adjustment techniques of curves based on reel tests.

$P_{gi}$ ,  $P_D$ ,  $T_L$  are respectively power active of  $i^{\text{th}}$

generator, total power load and total active power loss, all expressed in MW. Further,

$P_{gi}^{\min}$ ,  $P_{gi}^{\max}$ ,  $V_i^{\min}$  and  $V_i^{\max}$  represent the boundary

limits of active power and magnitude voltage.

The proposed method is a combination of GA and SLP, that is why it is called GASLP, it is consists to introduce the final results of controlled variables ( Power generator's outputs ) provided by SLP which give the optimal emission value as an initial population in GA method .this approach is illustrated in following figure:

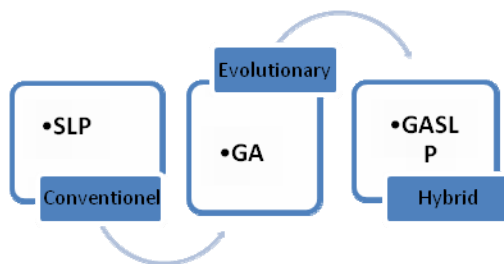

Fig. 2 Process of the hybrid GASLP approach

#### IV. TEST SYSTEM

The test system for this study is presented in Fig. 3, it is derived from IEEE\_30 test system; this network consists of 30 buses, 41 branches (37 lines and 4 transformers), 6 generators and 21 loads. The transformers connecting generators to the grid are adjusted accordingly.

It must be noted that the generators do not represent a single machine but a group of strongly coupled generators and for this test system the limits total power is divided as shown in Table 1.

TABLE 1

Active Power Limits of Test System Generators

Bus_Generator N°	1	2	5	8	11	13
Power(MW) Upper	200	80	50	35	30	40
Power(MW) Lower	50	20	15	10	10	12

Parameters of GA:

Population Size : 100  
 Generation number : 50  
 Crossover Fraction : 0.9 (two points)  
 Selection Function : roulette  
 Mutation Fraction : 0.08(uniform)

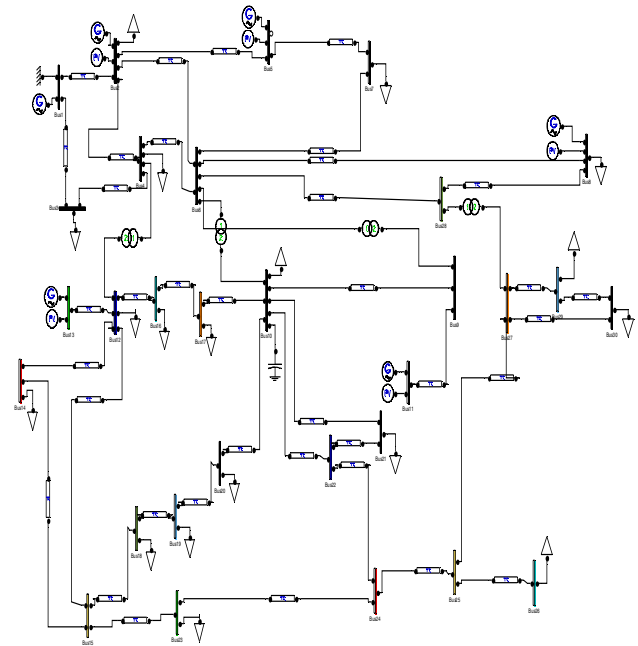

Fig.3 Test system model

#### V. RESULT AND DISCUSSION

The Base Case represents the normal operation of the system. The goal of optimization power flow in this study is looking for a minimal value of emission function without violation of limits noted above using successive linear programming SLP method on MATHPOWER 3.2 version which based on this method in OPF calculation.

Best: 195.3625 Mean: 197.1148

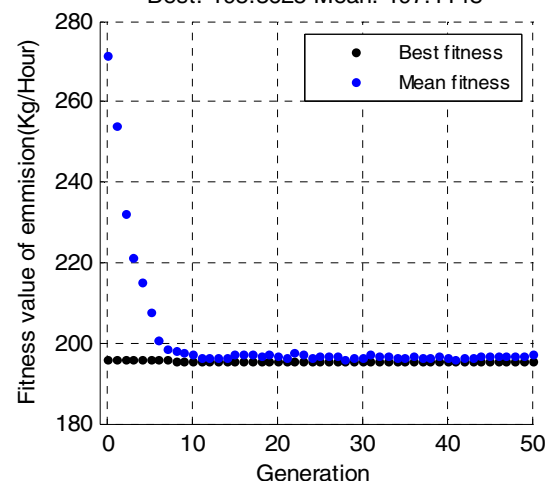

Fig. 4 Optimal emission function with ordinary GA

The optimal value of emission function computed with ordinary GA is 195.3625 Kg/hour otherwise the

same function is equal to 198.6414, when we introduce the vector of generation power Obtained via SLP method (MATPOWER) as initial population in GA program we obtained the results shown in fig.5.

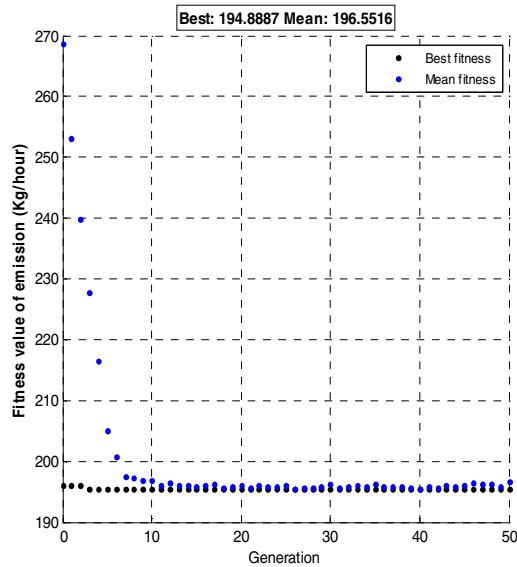

Fig. 5 Optimal emission function with GASLP

All results are assembled in following table:

TABLE 4

Optimal Outputs Values of Different Methods

	SLP	GA	PROPOSED GASLP
<b>P1 (MW)</b>	145.4089	59.6857	60.6521
<b>P2 (MW)</b>	41.4023	75.9923	71.3153
<b>P5 (MW)</b>	16.2065	47.6011	50.0000
<b>P8 (MW)</b>	22.7422	33.8841	35.0000
<b>P11 (MW)</b>	16.2767	29.9422	<b>30.0000</b>
<b>P13 (MW)</b>	39.9171	39.9743	40.0000
<b>TL (MW)</b>	03.5557	03.6796	03.5674
<b>FE (KG/H)</b>	198.6416	195.3625	194.8887

The following figure demonstrates that the optimal value of gas emission is calculated without violation of constraints of voltage because all voltage values of 30 buses are within allowed limits. Therefore the power generations for all unit production are within their limits, then we can confirm now that the GASLP

approach give a better optimal value of gas emission function than GA and SLP methods without any violation.

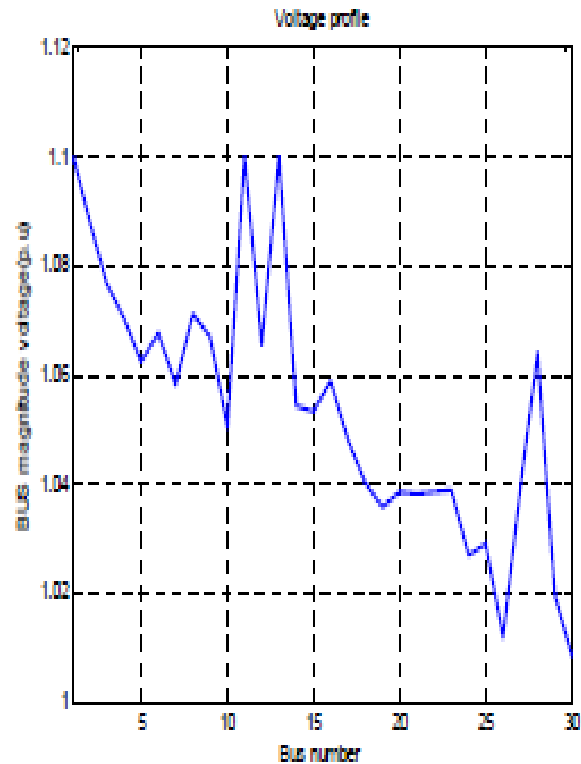

Fig. 6 Voltage profile

## VI CONCLUSION

Reducing power greenhouse gas emission has become a major challenge in the design and operation of today's computer systems. The recent studies on evolutionary algorithms have shown that the evolutionary algorithms as genetic algorithm are potential candidate to solve optimization problems and can be efficiently used to eliminate most of the difficulties of classical methods. In this paper, a hybrid procedure is introduced for environmental power dispatch problem. The problem has been formulated as an optimization of emission gas problem with two methods: one represented an evolutionary one(GA) and another classic or conventional as successive linear programming (SLP) singularly, the results are compared with a hybrid method called GASLP developed in this paper applied on a case study based on the standard IEEE 30-bus system. The results show that the proposed approach is efficient for solving such problems when it can contribute to reduce the greenhouse gas emission which no one unknown its impact on atmosphere pollution. In future, our work will consider applying this approach to other kind of multi-objective power systems.

## REFERENCES

- [1] Onishi A. "The impact of CO<sub>2</sub> emissions on the world economy: Policy simulations of FUGI global model". *J Policy Model* 2007;29:797–819.
- [2] V.M.F. Mendes, S.J.P.S. Mariano, J.P.S. Catalao, et al., "Emission constraints on short-term schedule of thermal units", 39th UPEC Proceeding, 2004, pp.1068–1072.
- [3] V. Vahidinasab, S. Jadid "Joint economic and emission dispatch in energy markets: A multiobjective mathematical programming approach", *Energy* 35, Elsevier (2010) 1497–1504
- [4] J.P.S. Catalão a, , S.J.P.S. Mariano a, V.M.F. Mendes b, L.A.F.M. Ferreira, A practical approach for profit-based unit commitment with emission limitations, *Electrical Power and Energy Systems* 32 Elsevier (2010) 218–224
- [5] Fan Y, Liu LC, Wu G, Wei YM. "Analyzing impact factors of CO<sub>2</sub> emissions using the STIRPAT model". *Environ Impact Assess Rev* 2006;26:377–95
- [6] Onishi A. "The impact of CO<sub>2</sub> emissions on the world economy: Policy simulations of FUGI global model". *J Policy Model* 2007;29:797–819.
- [7] J.H. Holland, "Adaptation in Natural and Artificial Systems", University of Michigan Press, 1975.
- [8] Alsac O, Bright J, Prais M, Stott B. Further developments in LP-based optimal power flow. *IEEE Trans Power Syst* 1990;5(3):697–711
- [9] R. D. Zimmerman, C. E. Murillo-Sánchez, and R. J. Thomas, "MATPOWER's Extensible Optimal Power Flow Architecture," *Power and Energy Society General Meeting, 2009 IEEE*, pp. 1-7.
- [10] Mitchell M., "An Introduction to Genetic Algorithms", The MIT Press, Massachusetts, 1996.
- [11] W.A.Chang, R.S. Ramakrishna, "Elitism-based compact genetic algorithms", *IEEE Transactions on Evolutionary Computation* 7 (4) (2003) 367–385.
- [12] Mukherjee SK, Recio A, Doulegeris C. "Optimal power flow by linear programming based optimization" *Proceedings of the IEEE South east con '92*, Birmingham, Alabama, USA, vol. 2; 1992. p. 527–9.
- [13] Katmakar ,N. "a new polynomial time algorithm for linear programming" *combinatorica*, vol 4, n<sup>o</sup>4, pp373-395,1984.
- [14] Stott B, Marinho JL. "Linear programming for power system network security applications". *IEEE Trans Power Syst* 1979;PAS-98(3):837–48.